

ENKIN



OPERATING INSTRUCTIONS

PDM150

150W LED Intelligent Dimmer

- **Easy push button setup**
- **Trailing/Leading Edge**
- **Soft start feature**
- **Silent & flicker free**
- **Self Recovering Thermal Fuse**
- **Short Circuit & Overload Protection**

Operating Voltage	240V ac
Nominal Operating Frequency	50 Hz
Dimming Technique	Trailing & Leading edge phase control
Compliance	BS EN 60669-2-1

Load Symbol	Compatible Loads	Max Load	Min Load
	Dimmable LED lighting	150W TE 100W LE	2W
	240V Incandescent & Halogen lamps	300W TE 100W LE	2W
	Low voltage lighting with electronic transformers	300W TE 100W LE	2W

Multi-Gang Switch De-Rating Chart

1 Gang	2 Gang	3 Gang	4 Gang	5 Gang
150W	127W	105W	82W	60W

ON OFF & DIMMING FUNCTION

Dimmer switch is activated by pressing the dimmer shaft only, dimming function by rotating the dimmer shaft only.

REAR PANEL PRESS BUTTON - DIMMER SETUP SEQUENCES

Setting the Minimum Level

1. Whilst on, slowly adjust dimmer to your desired minimum brightness.
2. Push the rear setup button 3 times within 2 seconds.
3. The LEDs will step up and down in brightness once to confirm the setting has been saved.

Setting the Maximum Level

1. Whilst on, slowly adjust dimmer to your desired maximum brightness.
2. Push the rear setup button 5 times within 3 seconds.
3. The LEDs will step up and down in brightness once to confirm the setting has been saved.

Factory reset for Min/Max brightness

Please note this factory reset will reset all the min and max brightness settings.

1. Whilst on, push the rear setup button 7 times within 5 seconds.
2. The LEDs will step up and down in brightness three times to confirm that the min/max setting has been cleared.

Changing the Dimming Mode

The default mode of the dimmer is Trailing Edge, but it can be put into Leading Edge if required. Please ensure that you know the correct mode for your lamp.

1. Whilst on, push the rear setup button 9 times within 5 seconds.
2. The LEDs will step up and down in brightness twice to confirm the setting has been changed to Leading Edge mode.

NOTE:

To switch back to Trailing Edge mode, just repeat the process again, the LEDs will step up and down once to show the dimmer is back in Trailing Edge mode.

WIRING DIAGRAM - ONE WAY

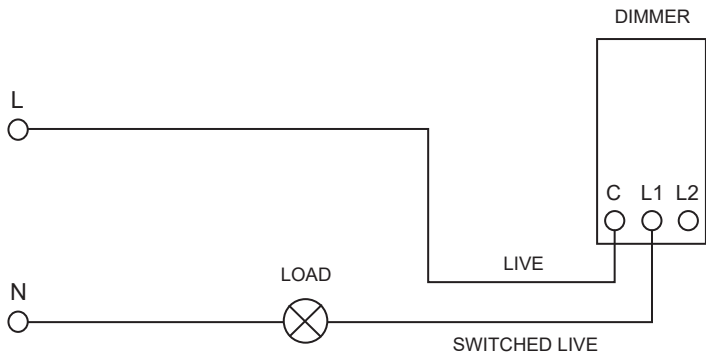

WIRING DIAGRAM - TWO WAY

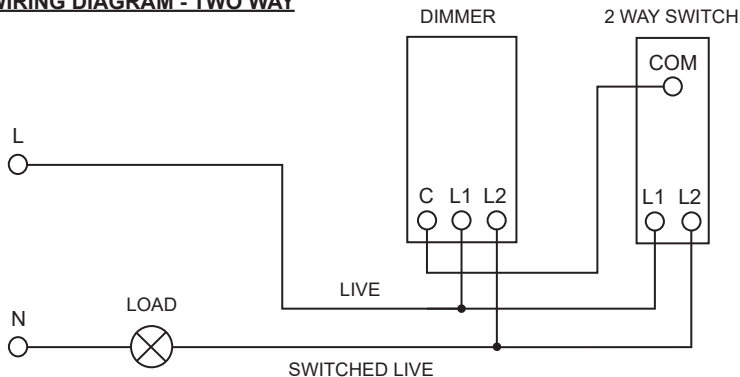

Scan QR Code for more detailed technical information on this product

www.enkin.com

UK
CA

CE



IP20



WARNING - PLEASE READ



RISK OF ELECTRIC SHOCK

- Hazardous voltage and electrical current may be present at the wire leads of this product even when the device is switched off.
- Lock out and tag the input circuit before accessing the wiring connections.
- This device must be installed by a qualified and experienced electrician in accordance with applicable current electrical regulation.
- To comply with all safety standards, the product must be used only for the purpose described in this instruction and must be installed in accordance with the wiring rules and regulation in the location where it is installed.
- There are no user serviceable parts inside the product. Failure to follow these instructions can result in death or serious injury.

EQUIPMENT DAMAGE HAZARD

- Install the device according to instructions in this document.
- Pay attention to the specifications and wiring diagrams related to the installation.
- Do not use this product for any other purpose than specified in this instruction.
- The product is suitable for indoor use only.
- Apply IEC60898-1 compliant 250V~ 6A MCB as an overload protective device.

ENVIRONMENTAL PROTECTION

Waste electrical products should not be disposed of with household waste. Please recycle where facilities exist. Check with your local authority or retailer for recycling advice.

LEGAL DISCLAIMER

The installation of electrical products is inherently dangerous and can lead to serious injury or death. The products we sell MUST be installed by a qualified and experienced electrician in accordance with applicable current electrical regulation. Any advice, guidance or other information provided by Enkin on their website or within any of our publications cannot completely anticipate your situation and common sense must prevail. Products need to be checked prior to installation and regularly for damage and wear and tear. Products should be returned and not used if in any doubt of their integrity.

Electrical rated loads and limits of a given product should NEVER be exceeded at any time. The electricity supply should always be isolated at its source (Distribution Board) before attempting any installation or maintenance.

No advice or information, whether oral or written, obtained by you from us or through the service, our employees, consultants and/or retailers shall create any warranty not expressly made herein.

You agree to assume all and any risk resulting from the utilisation of information provided by Enkin. You also expressly agree not to hold us responsible for any damage, personal injury, death or loss resulting from your use of our information, service or regulatory compliant products.

Enkin is a trading name of Trade Ivy. Registered in England Number: 10809945. Copyright © 2021 All Rights Reserved. Trade Ivy Limited, Unit 3C Latham Park, St Blazey Road, Par, PL24 2HY.