

PUSHKA HOME

SWITCHABLE. YOUR WAY.

Before you get started - we promise to be quick - we wanted to introduce our range of Switches and Sockets to make sure you have the products to effortlessly enhance your home.

At Pushka Home each product is carefully considered, every collection specifically curated. Our range of Rocker Switches, Dimmer Switches and Sockets are designed to be switchable across a wide variety of metal, colours and finishes.

All of our products are purposed to turn the functional into the feature and make your home, yours.

SAFETY.

Please read the following information carefully before commencing installation.

To prevent the possibility of receiving an electric shock, please ensure the isolator on the consumer unit / fuse board is in the 'OFF' position.

All our products must be installed in accordance with the latest amendment of IEE Wiring Regulations, BS 7671 and the following compliance codes:

ROCKER SWITCHES
EN 60669-1:1999+A1:2002+A2:2008
// IEC 60669-1:2017

DIMMER SWITCHES
IEC 60669-2-1:21st
// EN 60669-2-1:2004+A1:2009+A12:2010

SOCKETS
BS 1363-2:2016+A1:2018

All work undertaken should be carried out by a qualified electrician and adhere to the Electricity at Work Regulations 1989 and associated H&S practices.

INSTALLATION

ROCKER SWITCHES, DIMMER SWITCHES AND SOCKETS

INSTALL TO WALL

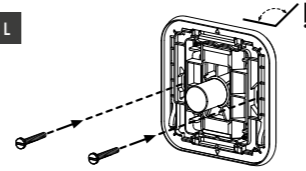

1. Using the screws provided install the product to the back box ensuring the product is level and flush to the wall.

FRONT FACIA REMOVAL / INSTALL

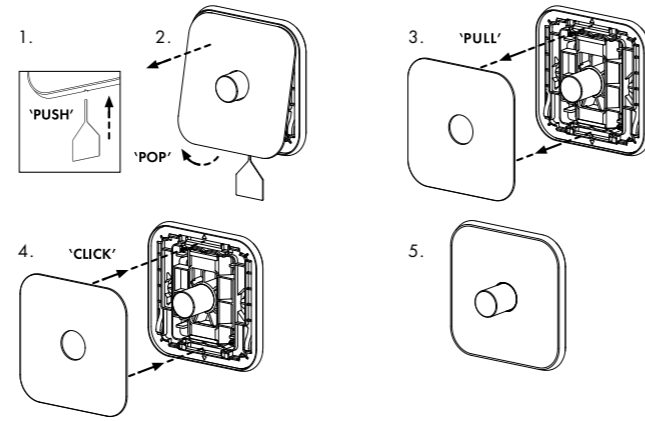

1. To remove the front fascia, use the install key, insert into the hole located at the base of the product as shown.
2. Apply pressure using the install key in a vertical motion for the front fascia to release and pivot away from the product.
3. With the front fascia released, hold the front fascia and pull away from the product to remove.
4. To install the front fascia, line up to product and push until the clips are fully engaged.
5. Once installed, check the front fascia is secure to product.

INSERT REMOVAL / CONVERSION

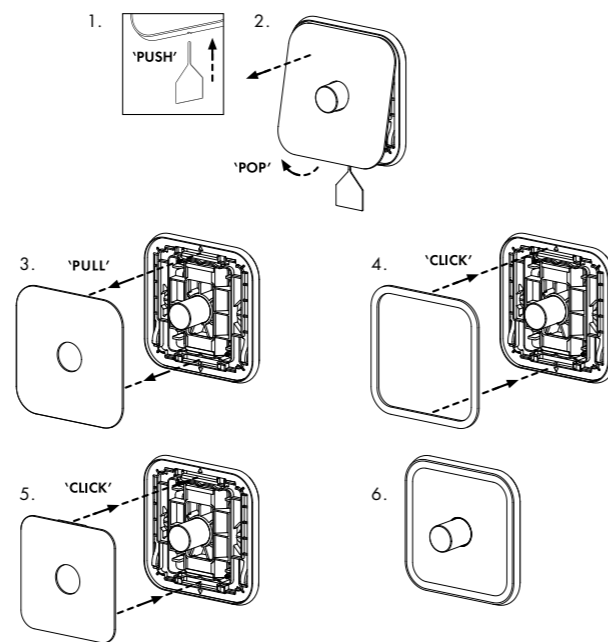

1. To remove the front fascia, use the install key, insert into the hole located at the base of the product as shown.
2. Apply pressure using the install key in a vertical motion for the front fascia to release and pivot away from the product.
3. With the front fascia released, hold the front fascia and pull away from the product to remove.
4. Inserts magnetically fit to the product. Line up and present the insert to the product in the areas shown and the insert will attach.
5. To install the front fascia, line up to the product and push until the clips are fully engaged.
6. Once installed, check the front fascia and insert is secure to the product.

ROCKER SWITCH

1G, 2G, 3G, 4G

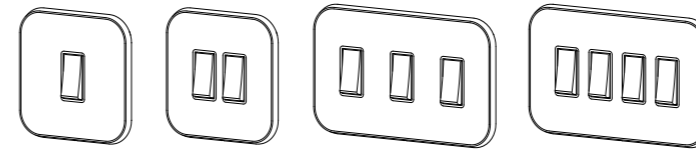

ROCKER SWITCH TECHNICAL SPECIFICATION

VOLTAGE	240V ~ 50HZ
Current Rating	1 Way, 2 Way Switches : 20AX Double Pole Switches : 20A Flex Outlet Module : 20A
Terminal Size	4.8mmø
Torque Value	Terminal Screw : 1.2Nm
Cable Size	3 x 2.5mm ² , 2 x 4mm ² , 1 x 6mm ²
Black Box Depth (Min)	25mm (Mode, Polar, Deco, Deco +) 35mm (Define, Definity)
Operational Temperature	-5°C to + 45°C
Standards	Switch Modules : BS EN 60669-1 Indicator Modules : BS 5733 Flex Outlet Module : BS 5733

ROCKER SWITCH INSTALLATION INSTRUCTIONS

All work undertaken should be carried out in accordance with the latest IEE Wiring Regulations, BS 7671 by a qualified electrician and adhere to the Electricity at Work Regulations 1989 and associated H&S practices. Ensure the mains isolator on the consumer unit / fuse board is in the 'OFF' position prior to install.



ROCKER SWITCH WIRING DIAGRAM

ONE WAY SWITCHED CIRCUIT

One way switching is when a single switch is used to control a single circuit. Typically, a one way switch will be used but a two way switch can also be used. To use a two way switch on a one way circuit use only the common and L1 terminals.

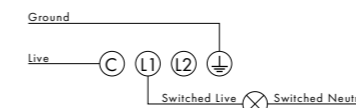

INTERMEDIATE SWITCHED CIRCUIT

An intermediate switch allows for multiple switches (two or more) to be used on a single circuit, meaning a circuit can be turned on or off from different locations.

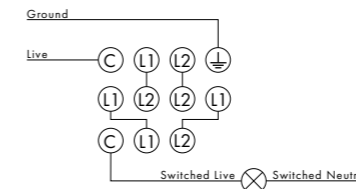

TWO WAY SWITCHED CIRCUIT

Two way switching is when a single circuit is controlled by two switches, enabling the user to control the circuit from two locations.

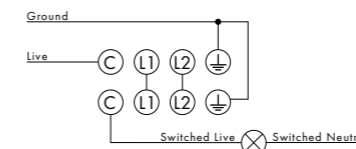

ROCKER SWITCH MODULE REMOVAL

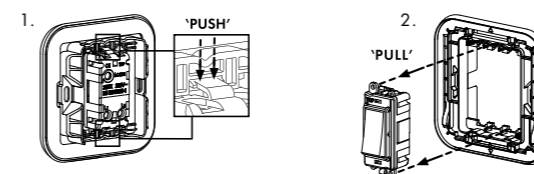

1. To remove the Rocker module from the product, firmly push on the tabs shown at the product rear and the module will release.
2. Once, released the Rocker module can be removed from the front of the product.



1-2G SOCKETS
1-4G DIMMER SWITCHES
1-4G ROCKER SWITCHES

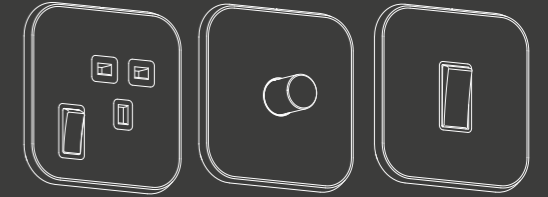

THE DETAILS
PUSHKA HOME



#pushkahome | @pushkahome | pushkahome.com

Unit 5A,
Shannon Commercial Centre,
Beverley Way, New Malden,
Surrey, KT3 4PT

0203 056 7556
contactus@pushkahome.com | pushkahome.com



DIMMER SWITCH

1G, 2G, 3G, 4G

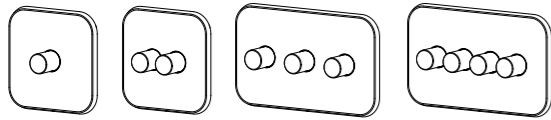

DIMMER SWITCH TECHNICAL SPECIFICATION

MARKINGS & STANDARD(S)	CE, UKCA, BS EN 60669-2-1
Operating Voltage	220 – 240V AC
Main Frequency	50Hz
Min Load	2W LED (Incandescent / Halogen)
Max Load	150W LED (Incandescent / Halogen)
Switch Type	Two Way
Dimming Protocol	Trailing Edge & Leading Edge Phase Control
Mounting Box Depth (Min)	35mm
Terminal Capacity	0.75 - 1.5mm ²
Terminal Markings	C (Live), L1 (Switched Live), L2 (2 Way)
Neutral Required	No
Short Circuit Protection	Yes
Overload/Overcurrent Protection	Yes
Thermal Protection	Yes – Thermal Resettable Fuse
Soft Start	Yes
Power Failure	Previous State Recall
Memory	Non Volatile
Min/Max Level Setting	Yes – Following a Defined Procedure
Driving Mode	Yes – Trailing Edge & Leading Edge Mode Change Following a Defined Procedure
Product Dimensions	60.5mm x 14mm x 25mm
IP Rating	IP2XD



LOAD SYMBOL	COMPATIBLE LOADS	MAX LOAD	MIN LOAD
	Dimmable LED lighting	150W TE 100W LE	2W
	240V Incandescent & Halogen Lamps	300W TE 100W LE	2W
	Low Voltage Lighting with Electronic Transformers	300W TE 100W LE	2W

MULTI-GANG SWITCH DE-RATING CHART – LED LIGHTING

1 GANG	2 GANG	3 GANG	4 GANG	5 GANG
150W	127W	105W	82W	60W

DIMMER SWITCH INSTALLATION INSTRUCTIONS

All work undertaken should be carried out in accordance with the latest IEE Wiring Regulations, BS 7671 by a qualified electrician and adhere to the Electricity at Work Regulations 1989 and associated H&S practices. Ensure the mains isolator on the consumer unit / fuse board is in the 'OFF' position prior to install.

DIMMER SWITCH WIRING DIAGRAM

ONE WAY DIMMER CIRCUIT

One way switching is when a single switch is used to control a single circuit. Typically, a one way switch will be used but a two way switch can also be used. To use a two way switch on a one way circuit use only the common and L1 terminals.



TWO WAY DIMMER CIRCUIT

Two way switching is when a single circuit is controlled by two switches, enabling the user to control the circuit from two locations.

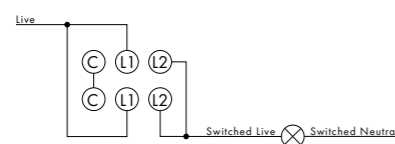

DIMMER SWITCH MODE SETTING

ON / OFF & DIMMING FUNCTION

Dimmer switch is activated pressing the Dimmer shaft only, dimming function by rotating the Dimmer shaft only.

SETTING THE MAX LEVEL

1. Whilst on, slowly adjust Dimmer to your desired maximum brightness.
2. Push the rear setup button 5 times within 3 seconds.
3. The LEDs will step up and down in brightness once to confirm the setting has been saved.

SETTING THE MIN LEVEL

1. Whilst on, slowly adjust Dimmer to your desired maximum brightness.
2. Push the rear setup button 3 times within 2 seconds.
3. The LEDs will step up and down in brightness once to confirm the setting has been saved.

FACTORY RESET FOR MIN / MAX BRIGHTNESS

Please note, this factory reset will reset all the min and max brightness settings.

1. Whilst on, push the rear setup button 7 times within 5 seconds.
2. The LEDs will set up and down in brightness 3 times to confirm that the min / max setting has been cleared.

CHANGING THE DIMMER MODE

The default mode of the Dimmer is Trailing Edge, but it can be put into Leading Edge if required. Please ensure that you know the correct mode for your lamp.

1. Whilst on, push the rear setup button 9 times within 5 seconds.
2. The LEDs will set up and down in brightness twice to confirm the setting has been changed to Leading Edge Mode.

NOTE: To switch back to Trailing Edge Mode, just repeat the process again, the LEDs will set up and down once to show the dimmer is back in Trailing Edge Mode.

DIMMER SWITCH MODULE REMOVAL

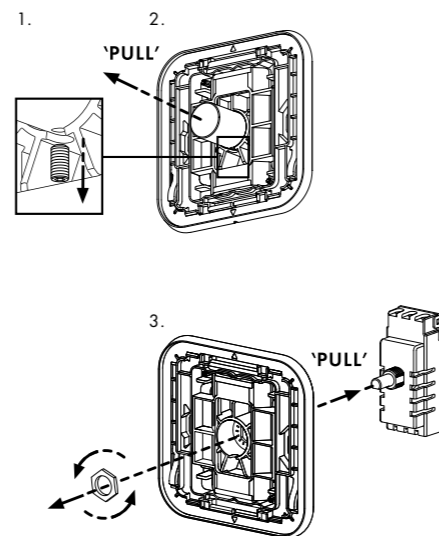

1. To remove the Dimmer module from the product, rotate the Dimmer knob so the grub screw faces downwards and with an allen key, remove the grub screw completely.
2. Once the grub screw is removed, the Dimmer knob can be removed by pulling it away from the product.
3. Once the Dimmer knob has been removed, remove the nut on the product front completely and the Dimmer module will remove from the product rear.

SOCKETS

1G, 2G

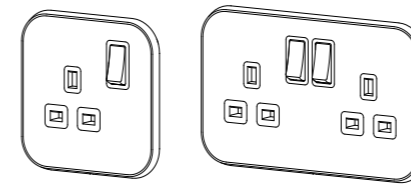

SOCKETS TECHNICAL SPECIFICATION

VOLTAGE	250V ~ 50HZ
Current Rating	13A
Terminal Size	5mmø
Torque Value	Terminal Screw : 2.0Nm
Cable Size	4 x 2.5mm ² , 2 x 4mm ²
Black Box Depth (Min)	25mm (Deco, Deco +, Mode, Polar, Part M, Curva) 35mm (Define, Definity)
Operational Temperature	-5°C to +45°C
Standards	The Low Voltage Directive 2014/35/EC Statutory Instruments 2014/35 BS 1363-2

SOCKETS INSTALLATION INSTRUCTIONS

All work undertaken should be carried out in accordance with the latest IEE Wiring Regulations, BS 7671 by a qualified electrician and adhere to the Electricity at Work Regulations 1989 and associated H&S practices. Ensure the mains isolator on the consumer unit / fuse board is in the 'OFF' position prior to install.



SOCKETS WIRING DIAGRAM

1 GANG 13A SWITCHED SOCKET

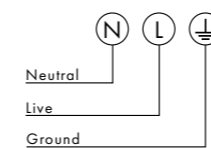

2 GANG 13A SWITCHED SOCKET

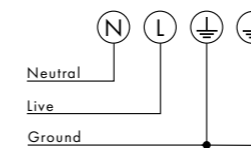

SOCKETS MODULE REMOVAL

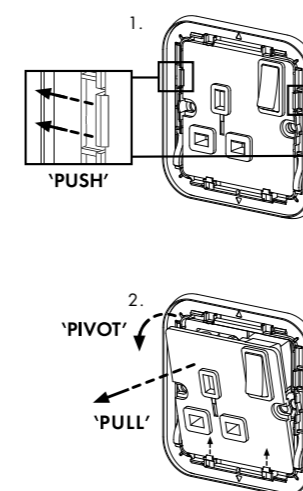

1. To remove the Socket module from the product, firmly push on the tabs shown at the product front and the module will release.
2. Once released, slide the Socket module up and pivot to release from the product front.

OUR PROMISE.

From the initial pencil sketch of a product through to the final lacquer process, our products are designed to delight and manufactured to stand the test of time.

We're so confident in our product, they come with a 2 year guarantee, and exceptional customer service.

After all, we're here to handle you with care too.

INFORMATION.

LEGAL

If the product fails within the guaranteed period. Pushka Home Ltd. will offer a free replacement (or nearest equivalent), but takes no responsibility for consequential loss or damage upon installation.

The guarantee period is invalid if:

- The product was damaged during fitting, accidental or malicious damage, improper use, general wear and tear, damage due to poor installation or consequential loss.

GUARANTEE

At Pushka Home Ltd. we believe in giving you uncompromising quality with our products guaranteed to last.

- All products come with a 2 year guarantee as standard.
- The guarantees are intended to cover the reasonably anticipated lifespan of goods and applies to the original purchaser and the original installation address only.
- The guarantee is non-transferable.

PRODUCT RESOURCES

We have created helpful datasheets to ensure you have all the information you need to achieve beautiful results and regulatory standards you're looking for.

Discover more at pushkahome.com